

# PLAN 1550

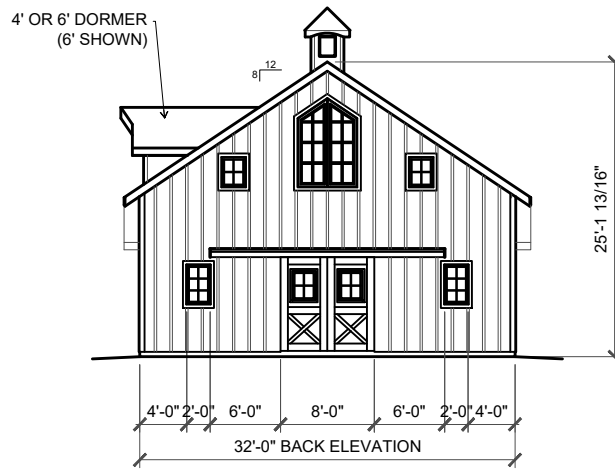
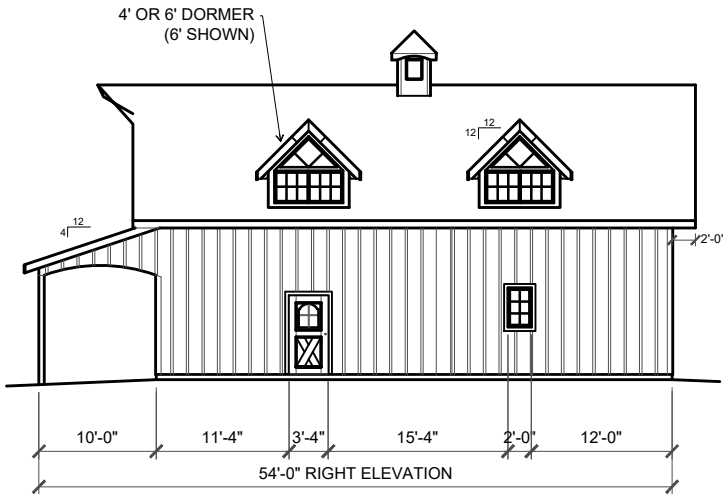
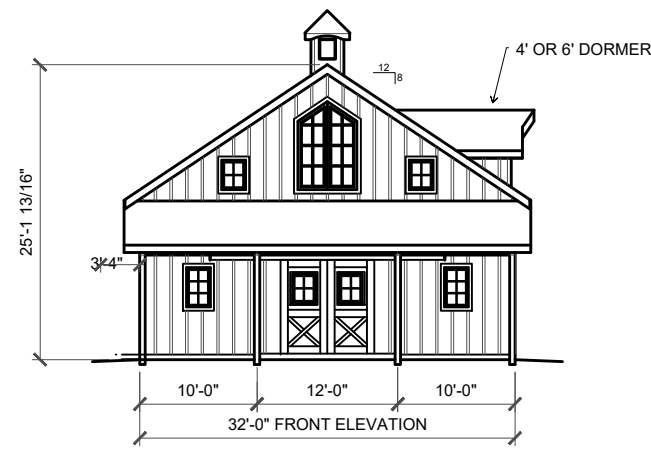
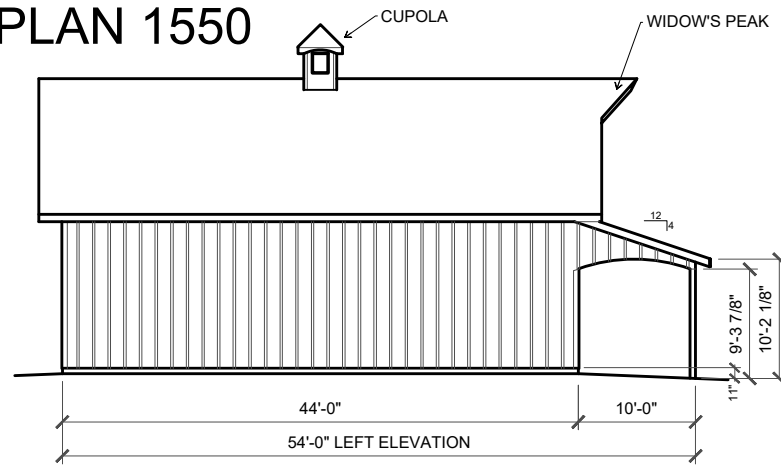

## Barn Factory Bundle Kit Quote

Picture #      Plan# 1550  
 Customer      Western Upper Sq. ft. 1408  
 cell      date 1/1 Classic Lower Sq. ft. 1728  
 email      zip      Total Sq. ft. 3136

Pre-made Item	Qty	Salesperson
Cupola	<input checked="" type="checkbox"/> Yes/No <u>1</u> <input checked="" type="checkbox"/> 4 sided <input type="checkbox"/> 6 sided	<u>Howard</u>
Widows peak	<input checked="" type="checkbox"/> Yes/No <u>1</u> Pitch <u>12</u> <input type="checkbox"/> standard <input type="checkbox"/> other	
Dormers	<input checked="" type="checkbox"/> Yes/No <u>2</u> gable <input checked="" type="checkbox"/> 4' <input type="checkbox"/> 6' <input type="checkbox"/> other <input type="checkbox"/> 4 or 6'	
Loft door	<input checked="" type="checkbox"/> Yes/No <u>2</u> Size <u>60x90</u> <input type="checkbox"/> windows <input checked="" type="checkbox"/> Yes/No <u>French</u>	
Alley doors	<input checked="" type="checkbox"/> Yes/No <u>0</u> Size <input type="checkbox"/> windows <input type="checkbox"/> Yes/No	
RV Garage doors	<input type="checkbox"/> Yes/No <u>0</u> Size <input type="checkbox"/> windows <input type="checkbox"/> Yes/No	
Carriage House doors	<input checked="" type="checkbox"/> Yes/No <u>2</u> Size <u>8x10?</u> <input type="checkbox"/> windows <input checked="" type="checkbox"/> Yes/No	
Man doors	<input checked="" type="checkbox"/> Yes/No <u>1</u> Size <u>3x8</u> <input type="checkbox"/> windows <input checked="" type="checkbox"/> Yes/No	
Stall door	<input type="checkbox"/> Yes/No <u>0</u> (Standard plans \$500 custom plans \$1000)	
Dutch Paddock door	<input type="checkbox"/> Yes/No <u>0</u> <b>19 PAGE PLANS ONLY \$</b>	
Stall front grill w/grill gate	<input type="checkbox"/> Yes/No <u>0</u> <b>OR... Barn bundle kit including Plans</b>	
Gossip grill	<input type="checkbox"/> Yes/No <u>0</u> <b>BUNDLE KIT \$ 9100</b>	
Stair way	<input checked="" type="checkbox"/> Yes/No <u>1</u> <b>lumber and hardware purchased locally</b>	
Barn window sizes	<input type="checkbox"/> Yes/No <u>9</u> <b>purchased Estimate \$ 26000</b>	

**Bundle kit Terms;** 1/2 to start \$ 4,550 balance when kit is ready \$ 4,550  
 If you are seriously considering purchasing the above **bundle kit** items and have more questions, please fill out the customer information above, and email Howard at [Barnfactory@gmail.com](mailto:Barnfactory@gmail.com) or text Howard at 360-470-4866  
 Thanks, Howard  
 "The old barn guy"

BARNFACTORY.COM  
 P.O. BOX 339  
 Oakville, Washington 98568  
 BARN PLANS AND  
 PREMADE ITEMS BUNDLE KITS  
 e-mail: barnfactory@gmail.com

**BARN FACTORY**  
 these plans are designed by and the property of Howard Horton. Copyright 2015-2023. All rights reserved. This architectural plan and all derivative works are intended for one-time use only for Barn Factory customers unless otherwise expressed by written consent of copyright holder in accordance with 17 U.S.C. § 102. Any reproduction of this drawing for use on other projects, in whole or in part, is prohibited without the express written consent of the copyright holder and may be subject to compensation. This plan and all derivative works are general in nature and subject to modification by local code requirements. Review by a licensed engineer is recommended and may be required.  
 You the owner will need to provide the following from your local permit office:  
 Wind Load  
 Ground snow Load  
 Frost Depth  
 Seismic Zone  
 Plan Size 11x17 or 24x36  
 Site address

